

# SIEMENS

Drehimpulsgeber  
*Rotary pulse encoder*  
Codeur rotatif d'impulsion  
*Emisor de impulsos (encoder)*  
Encoder impulsi di rotazione  
*Momentgevare*

**1XP8001-1**  
**1XP8001-2**

Montageanleitung  
*Mounting Instructions*  
Instructions de montage  
*Instrucciones de montaje*  
Istruzioni di montaggio  
*Montageanvisning*

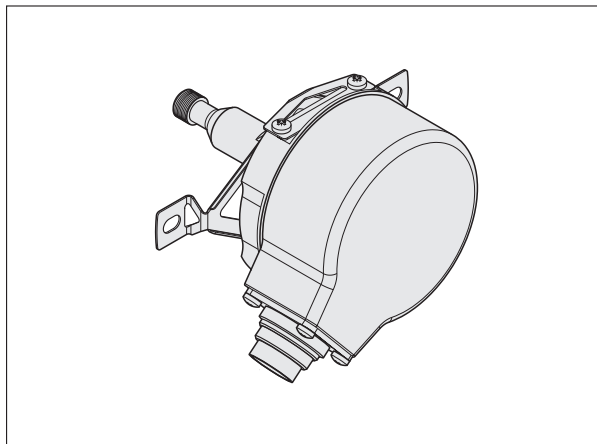

1/2005

© Siemens AG 1994 All Rights Reserved

**Bestell - Nr. / Order No. : 517.30777.30**

DEUTSCH / ENGLISH / FRANÇAIS / ESPAÑOL / ITALIANO / SVENSK



Maße in mm  
Dimensions in mm  
Cotes en mm  
Dimensioni in mm  
Dimensiones en mm  
Dimensioner i mm

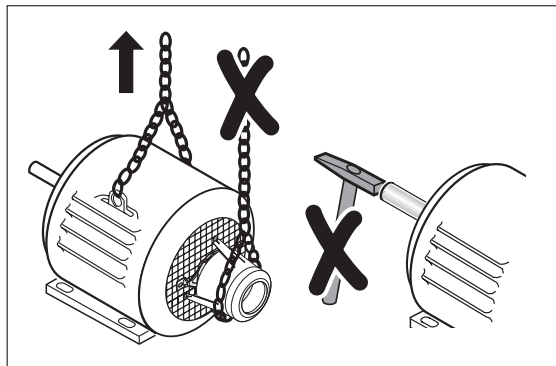
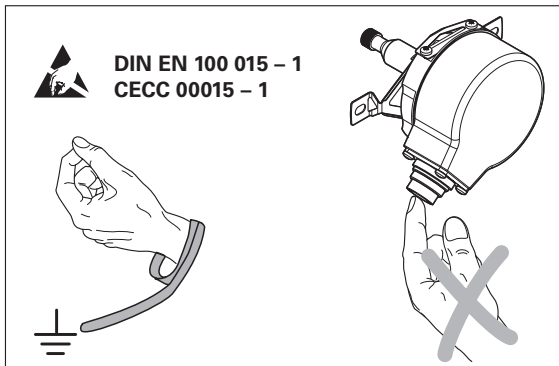
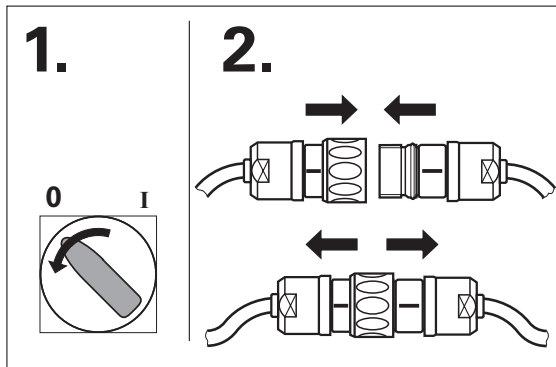

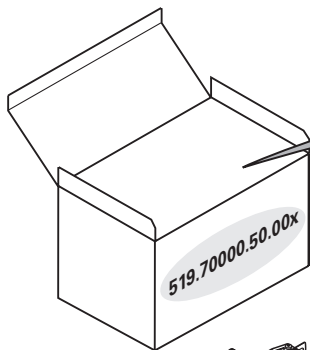

**Z = Strichzahl**  
*Line count*  
 Nombre de traits  
 Numero de impulsos  
 Numero di impulsi  
 Polser

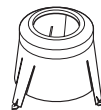
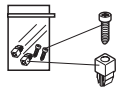
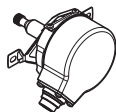

<b>519.70000.50.001</b>	1XP8001-1	1024	839.40000.01	839.40001.01	—	517.30777.30
<b>519.70000.50.002</b>	1XP8001-1	1024	—	839.40001.02	—	517.30777.30
<b>519.70000.50.003</b>	1XP8001-2	1024	839.40000.01	839.40001.01	099.20586.01	517.30777.30
<b>519.70000.50.004</b>	1XP8001-1	1024	839.40000.01	839.40001.01	099.20586.01	517.30777.30
<b>519.70000.50.005</b>	1XP8001-1	2048	839.40000.01	839.40001.01	099.20586.01	517.30777.30
<b>519.70000.50.006</b>	1XP8001-1	2048	—	839.40001.02	—	517.30777.30
<b>519.70000.50.007</b>	1XP8001-2	1024	—	839.40001.02	—	517.30777.30

mm



DIN ISO 8015  
ISO 2768 - m H

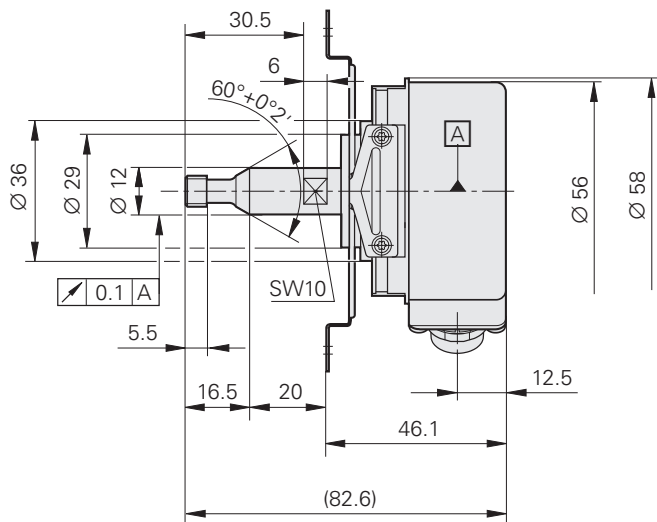

**A** = Lagerung  
Bearing  
Roulement  
Cuscinetto  
Rodamiento  
Lagring

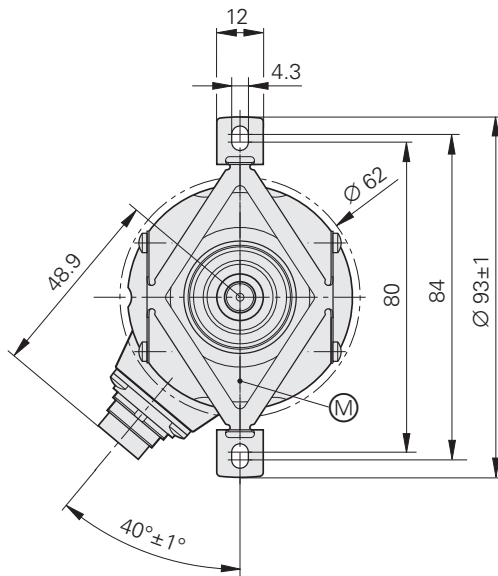

$\textcircled{M}$  = Messpunkt Arbeitstemperatur  
 Measuring point for operating temperature  
 Point de mesure température de travail  
 Punto di misura – temperatura di esercizio  
 Punto de medición de la temperatura de trabajo  
 Mät punkt för arbetstperatur

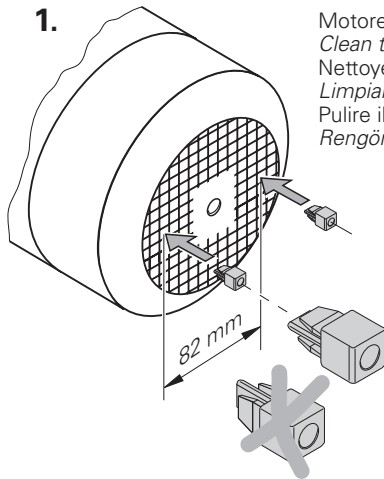
**1.**

Motorenwellenkonus und Innen-Gewinde reinigen  
 Clean the motor shaft taper and the internal thread  
 Nettoyer le cône de l'arbre du moteur et le filetage interne  
 Limpiar el cono del eje del motor y la rosca interna  
 Pulire il cono ricavato sull'albero motore e la filettatura interna  
 Rengör motoraxelkona och invändig gänga

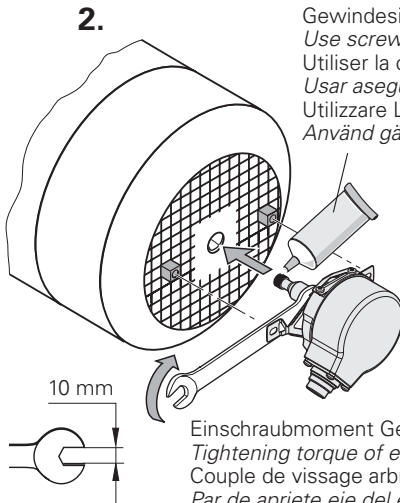
**2.**

Gewindesicherung Loctite 243 verwenden  
 Use screw retaining compound Loctite 243  
 Utiliser la colle de filetage Loctite 243  
 Usar asegurador de tornillo Loctite 243  
 Utilizzare Loctite 243 sulla filettatura di fissaggio  
 Använd gänglåsning Loctite 243

Einschraubmoment Geberwelle  $M_d \leq 7 \dots 9 \text{ Nm}$   
 Tightening torque of encoder shaft  $M_d \leq 7 \dots 9 \text{ Nm}$   
 Couple de vissage arbre moteur  $M_d \leq 7 \dots 9 \text{ Nm}$   
 Par de apriete eje del encoder  $M_d \leq 7 \dots 9 \text{ Nm}$   
 Forza di serraggio dell'albero dell'encoder  $M_d \leq 7 \dots 9 \text{ Nm}$   
 Åtdragningsmoment givaraxel  $M_d \leq 7 \dots 9 \text{ Nm}$

3.

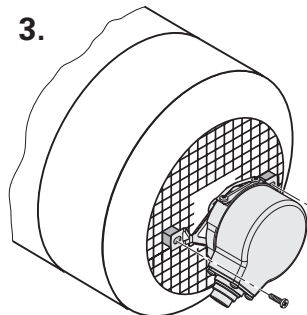

Einschraubmoment Momentenstütze (2x)  $M_d \leq 2 \text{ Nm}$   
Tightening torque of torque support (2x)  $M_d \leq 2 \text{ Nm}$   
Couple de vissage supports pour couple de rotation (2x)  $M_d \leq 2 \text{ Nm}$   
Par de apriete soporte de apoyo (2x)  $M_d \leq 2 \text{ Nm}$   
Forza di serraggio delle viti (2x)  $M_d \leq 2 \text{ Nm}$   
Åtdragningsmoment vridstöd (2x)  $M_d \leq 2 \text{ Nm}$

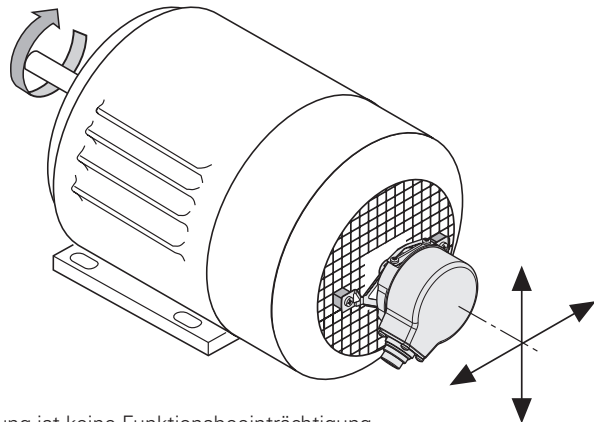
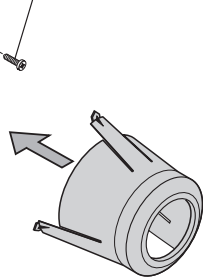
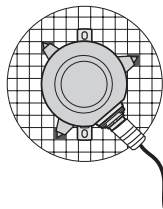
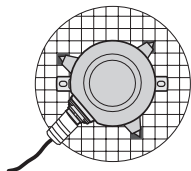

Die leichte Taumelbewegung ist keine Funktionsbeeinträchtigung  
The light wobble does not impair proper function  
Une légère nutation n'est pas préjudiciable au fonctionnement  
El ligero movimiento de vaivén no afecta al correcto funcionamiento  
Un errore di eccentricità nella rotazione dell'albero non comporta fluttuazioni nella misura  
Ett litet kast är inget funktionshinder

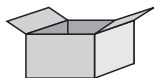
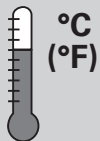

-40 ... 80 °C  
(-40 ... 176 °F)

**UL certification**  
**File no. E197018**

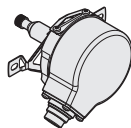

1XP8001-1 /  $U_P = 10 \dots 30 \text{ V}$   
 1XP8001-2 /  $U_P = 5 \text{ V} \pm 10 \%$

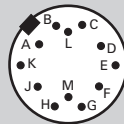

A	B	C	D	E	F	G	H	Schirm Shield Blindage Blindaje Schermo Skärm	K	L	M
$\overline{U_{a2}}$	$U_P$	$U_{a0}$	$\overline{U_{a0}}$	$U_{a1}$	$\overline{U_{a1}}$	$\overline{U_{aS}}$	$U_{a2}$		0V	0V	$U_P$

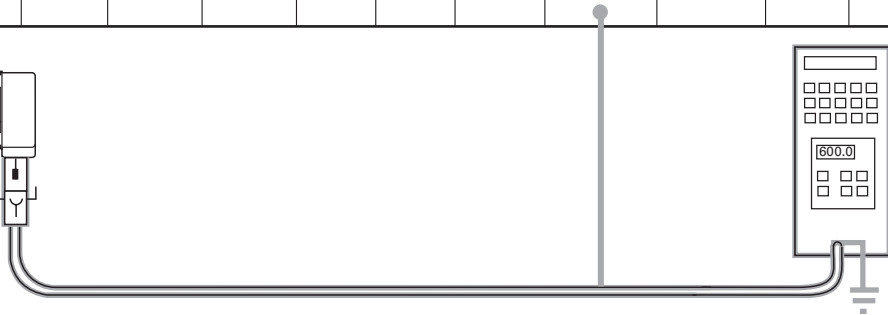
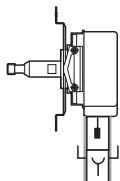

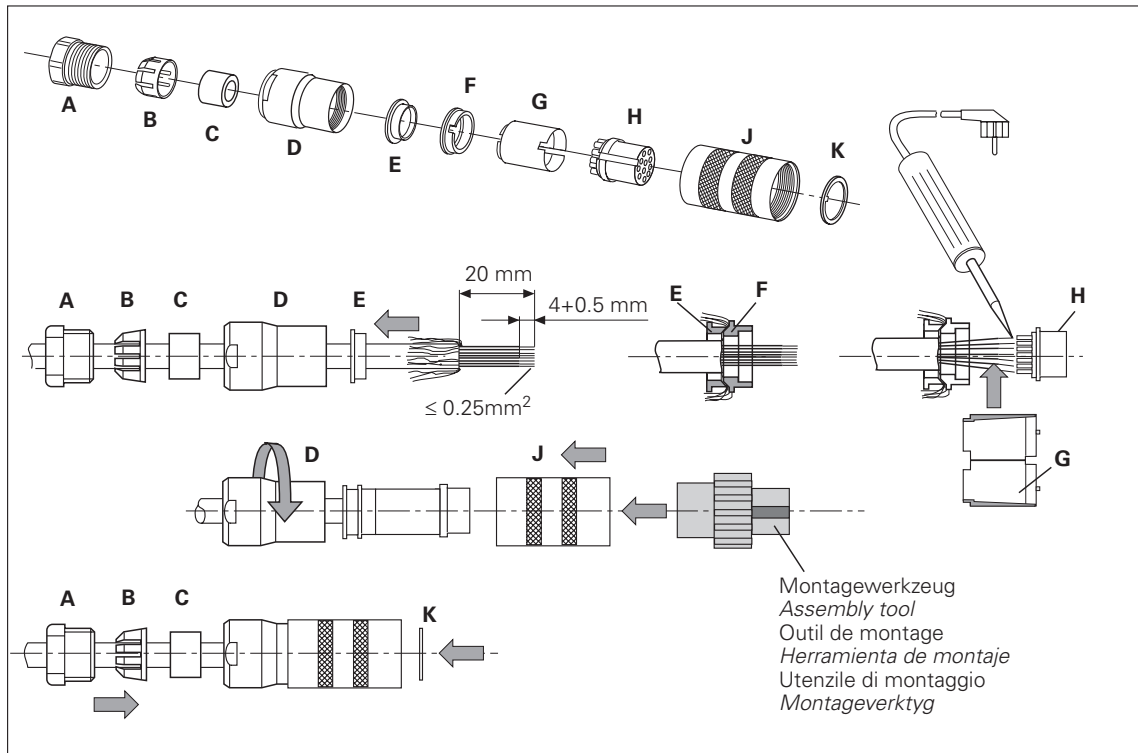

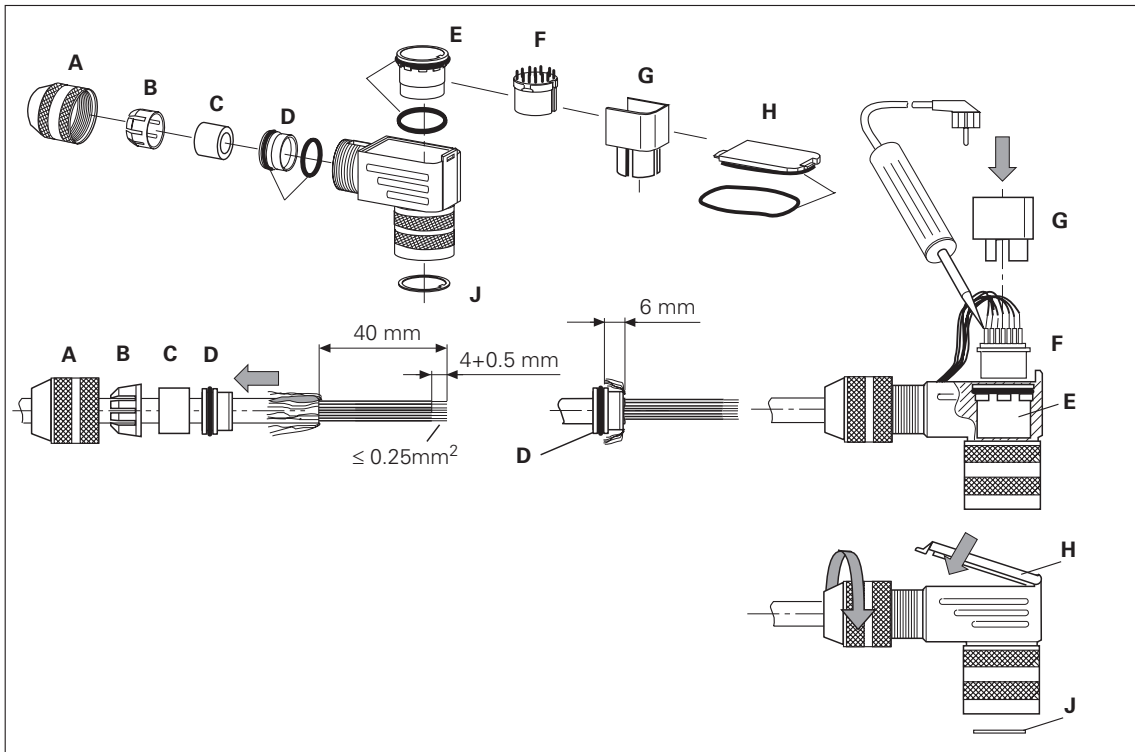

# 1XP8001-1

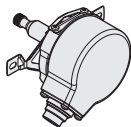

$L \leq 200 \text{ m}$   $U_P = 12.75 \dots 15.75 \text{ V}$  (max. 200 mA,  $U_{a1}$ ,  $U_{a2}$ ,  $U_{a0}$ ,  $\overline{U_{aS}}$ )

$L \leq 300 \text{ m}$   $U_P = 10 \dots 30 \text{ V}$  (max. 350 mA,  $\frac{U_{a1}}{U_{a1}}, \frac{U_{a2}}{U_{a2}}, \frac{U_{a0}}{U_{a0}}, \overline{U_{aS}}$ )



EN 50 178/4.98; 5.2.9.5

IEC 364-4-41: 1992; 411 (PELV/SELV)

$$n [\text{min}^{-1}] \leq \frac{f_{\text{max}} [\text{kHz}]}{Z} \cdot 10^3 \cdot 60 \text{ min}^{-1} \begin{cases} L \leq 100 \text{ m} & f_{\text{max}} \leq 160 \text{ kHz} (U_{a1}, U_{a2}, U_{a0}, \overline{U_{aS}}) \\ L \leq 200 \text{ m} & f_{\text{max}} \leq 120 \text{ kHz} (U_{a1}, U_{a2}, U_{a0}, \overline{U_{aS}}) \\ L \leq 300 \text{ m} & f_{\text{max}} \leq 160 \text{ kHz} (U_{a1}, U_{a2}, U_{a0}, \overline{U_{a1}}, \overline{U_{a2}}, \overline{U_{a0}}, \overline{U_{aS}}) \end{cases}$$

Z = Strichzahl

*Line count*

*Nombre de traits*

*Numero de impulsos*

*Numero di impulsi*

*Polser*

$f_{\text{max.}}$  = Abtastfrequenz

*Scanning frequency*

*Fréquence de balayage*

*Frequenza di scansione*

*Frecuencia de captación*

*Avkänningsfrekvens*

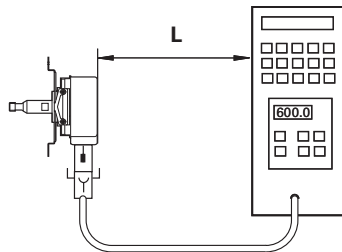
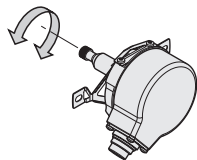

# 1XP8001-1

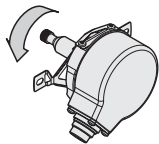

$\overline{U_{a1}}, \overline{U_{a2}}, \overline{U_{a0}}$   
 $\overline{U_{a1}}, \overline{U_{a2}}, \overline{U_{a0}}, \overline{U_{aS}}$

Strichzahl  
 Line count  
 Nombre de traits  
 Numero de impulsos  
 Numero di impulsi  
 Polser

} 1024

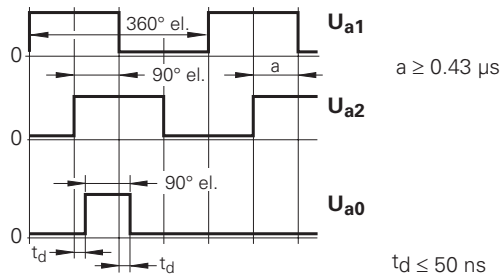

$\overline{U_{aS}}$ : Störungssignal  
 Fault detection signal  
 Signal de perturbation  
 Señal de avería  
 Segnale di malfunzionamento  
 Störsignal

$\overline{U_{aS}}$  = High: ✓

$\overline{U_{aS}}$  = Low:

## HTL

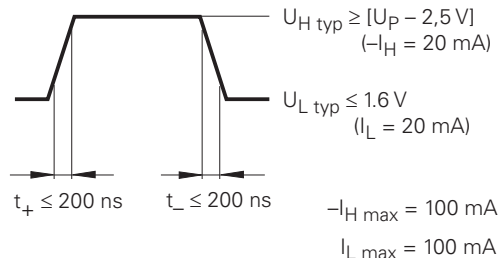

# 1XP8001-1

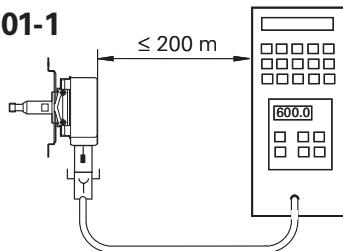

$U_{a1}, U_{a2}, U_{a0}, \overline{U_{aS}}$

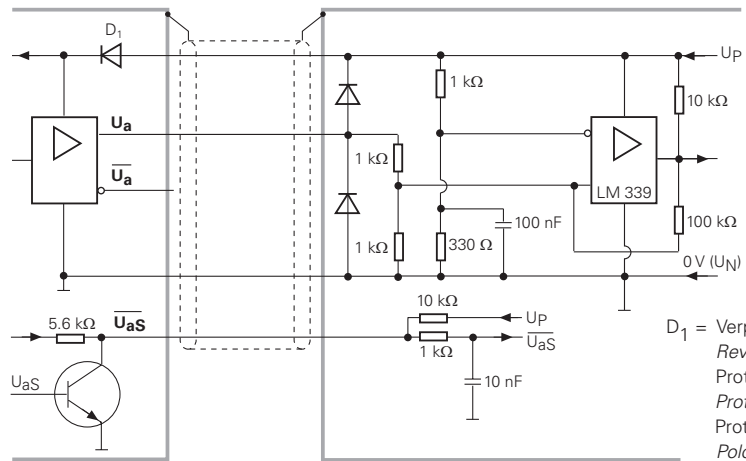

$D_1$  = Verpolschutz  
 Reverse polarity protection  
 Protection d'inversion de polarisation  
 Protección contra inversión de la polaridad  
 Protezione da inversione di polarità  
 Polomuāndningsskydel

# 1XP8001-1

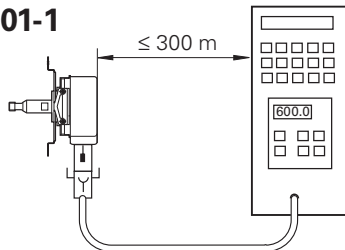

$U_{a1}, U_{a2}, U_{a0}$   
 $\overline{U_{a1}}, \overline{U_{a2}}, \overline{U_{a0}}, \overline{U_{aS}}$

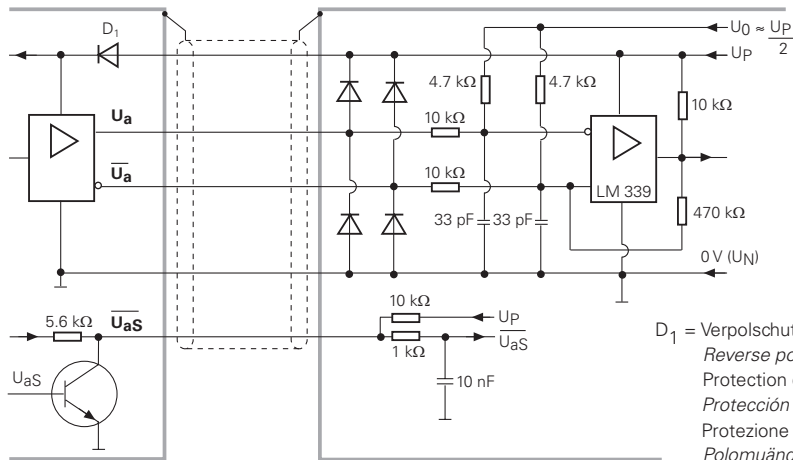

## 1XP8001-2

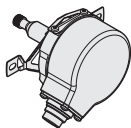

$U_P = 5\text{ V} \pm 10\%$  (max. 150 mA)



EN 50 178/4.98; 5.2.9.5  
IEC 364-4-41: 1992; 411(PELV/SELV)

$$n [\text{min}^{-1}] \leq \frac{300 [\text{kHz}]}{Z} \cdot 10^3 \cdot 60 \text{ min}^{-1} \leq 6\,000 \text{ min}^{-1}$$

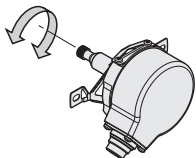

Z = Strichzahl  
*Line count*  
*Nombre de traits*  
*Numero de impulsos*  
*Numero di impulsi*  
*Polser*

# 1XP8001-2

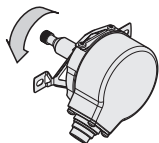

$\overline{U_{a1}}, \overline{U_{a2}}, \overline{U_{a0}}$   
 $\overline{U_{a1}}, \overline{U_{a2}}, \overline{U_{a0}}, \overline{U_{aS}}$

Strichzahl  
 Line count  
 Nombre de traits  
 Numero de impulsos  
 Numero di impulsi  
 Polser

} 1024

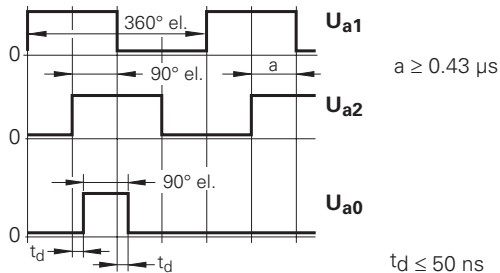

$\overline{U_{aS}}$ : Störungssignal  
 Fault detection signal  
 Signal de perturbation  
 Señal de avería  
 Segnale di malfunzionamento  
 Störsignal

$\overline{U_{aS}} = \text{High}$ : ✓

$\overline{U_{aS}} = \text{Low}$ :

## TTL

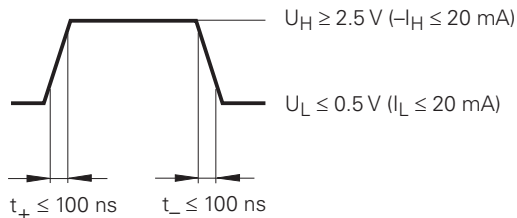

# 1XP8001-2

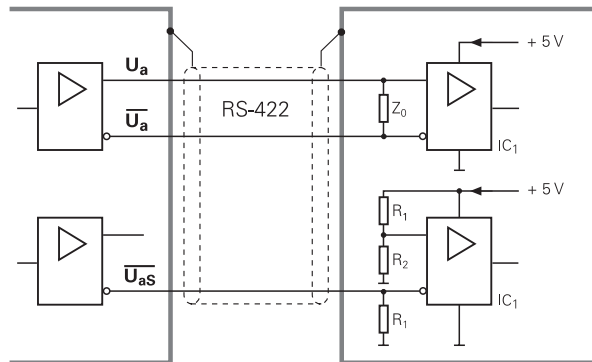
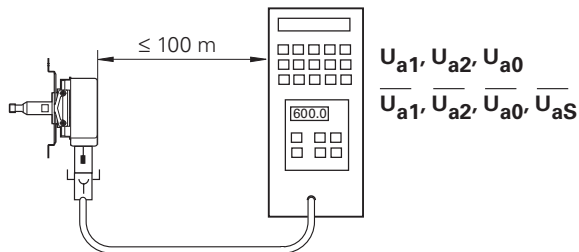

$IC_1$  = Differenzleitungsempfänger nach RS 422  
*Differential line receiver as per RS 422*  
 Récepteur différentiel de ligne selon RS 422  
*Ricevitore di linea differenziale secondo RS 422*  
 Receptor de la tensión diferencial según RS 422  
*Differenzledningsmottagare efter RS 422*

$R_1 = 4.7 \text{ k}\Omega$

$R_2 = 1.8 \text{ k}\Omega$

$Z_0 = 120 \text{ }\Omega$

AM 26 LS 32

MC 3486

SN 75 ALS 193

---

**Geschäftsgebiet**  
**Geschäftszweig**

**Automation & Drives**  
**Standard Drives**

**D-97615 Bad Neustadt an der Saale**



---

**Siemens Aktiengesellschaft**

**Bestell-Nr. / Order No.: 517.30777.30**  
Printed in the Federal Republic of Germany

533 406-91 · 30 · 1/2005 · F&W · Änderungen vorbehalten

*Subject to change without notice · Sous réserve de modifications · Sujeto a modificaciones · Con riserva di modifiche · Förbehåll för ändringar*

